

Technische Zeichnungen

Die Maße sind in Millimetern angegeben.

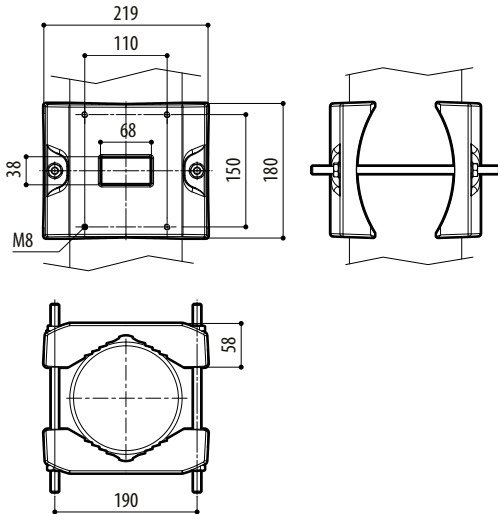

PTCC1

Support

Weitere Informationen und zusätzliche Dokumentation finden Sie unter pelco.com. Support zu einem bestimmten Produkt erhalten Sie per E-Mail unter support@pelco.com.

© 2026 Pelco, Inc. All rights reserved. MOTOROLA, MOTO, MOTOROLA SOLUTIONS, and the Stylized M Logo are trademarks or registered trademarks of Motorola Trademark Holdings, LLC and are used under license. Pelco, the Pelco logo, and other trademarks associated with Pelco products referred to in this publication are trademarks of Pelco, Inc. or its affiliates. All other trademarks are the property of their respective owners. Product specifications and availability are subject to change without notice.

MAR 2026 | | REV 2

PELCO